

Vissa

VENTILADORES INDUSTRIALES
COLECTORES DE POLVO

VENTAS INSTALACIONES Y SERVICIO, S.A.



VENTILADORES TUBO AXIALES CON TRANSMISIÓN DE POLEAS Y BANDA

Modelo AXB

Los equipos de la serie AXB son ventiladores tubo axiales de construcción reforzada, con aspas aerodinámicas y transmisión de poleas y banda, para trabajo pesado y continuo.

Son ideales para sistemas de ventilación y extracción industrial de baja presión, extracción en campanas, tanques de proceso, casetas de pintura, secado de materiales con aire pre-calentado, como desfogue de máquinas o enfriamiento de equipos o áreas específicas.

Estos ventiladores están recomendados para manejar aire con cantidades discretas de partículas o grasa, humos, vapores o gases, con temperaturas hasta de 100 grados centígrados.

Los rotores son aerodinámicos, para operar silenciosa y eficientemente. Tienen 4 u 8 aspas de acero de construcción hueca, con gran resistencia estructural y bajo peso, rígidamente soldadas a un centro de acero y balanceado dinámicamente. El rotor se fija fácilmente y de manera segura a la flecha del ventilador por medio de un buje cónico.

El cuerpo del ventilador está rígidamente soldado a cordón continuo para asegurar su hermetismo. Las bridas son de gruesa solera con barrenos estándar para su fácil instalación. La base del motor es ajustable para tensar las bandas y corre sobre una base fija, que refuerza y transfiere el peso uniformemente al cuerpo del ventilador.



Ventilador Modelo AXB tamaño 182-834, con rotor (opcional) de fundición de aluminio.

La transmisión va alojada dentro de un túnel para mantener las chumaceras, flechas, poleas y bandas aisladas del flujo de aire. Las graseras tienen extensiones para lubricar las chumaceras desde el exterior.

Por su tamaño compacto y por que se colocan directamente en el sistema de ductos, los ventiladores tubo axiales son mas fáciles de instalar que los centrífugos y sin necesidad de plataformas, transformaciones y codos.

Pueden fabricarse también, sobre pedido, en acero inoxidable o con recubrimientos especiales; en construcción antichispa, con registro para inspección, guardas de protección en la succión y descarga, cubrebandas, cubierta de intemperie para el motor, atenuador de ruido, soportes para colocarse en piso o colgarse.



Ventiladores Tubo Axiales

Transmisión de poleas y bandas

AXB

SELECCIÓN

Para seleccionar un ventilador tubo axial, es necesario saber el caudal que se quiere manejar y la presión estática requerida. Localice en el primer renglón de la tabla, la presión estática requerida y baje por esa columna hasta encontrar el caudal (PCM) deseado. A la izquierda, en la primera columna de la tabla, lea el modelo del ventilador, en la segunda, la potencia del motor (HP) y en la tercera las revoluciones a las que va a trabajar. El tamaño del ventilador, está en la esquina superior izquierda de la tabla.

Ejemplo: Seleccionar un ventilador tubo axial con transmisión de poleas y bandas para manejar 4,600 PCM, con una presión estática de 1/2" c.a.

Selección: Entrando en la tabla del tamaño 150, en el primer renglón ubicamos la columna que dice 1/2" c.a. Bajando por esa columna, llegamos hasta la casilla en donde dice 4,690 PCM (el volumen inmediato superior al requerido), y en ese renglón, leemos en la primera columna, que el modelo es el 834, en la segunda que necesita un motor de 2 HP y en la tercera, que el equipo debe girar a 3169 RPM.

El modelo del ventilador consta de tres cifras. La primera determina el número de aspas del rotor y las dos últimas su ángulo de ataque.

La descripción completa del ventilador seleccionado, será:

1. Tipo de ventilador: Tubo axial con poleas y bandas AXB
2. Tamaño del ventilador. (por ejemplo tam. 150)
3. Modelo (por ejemplo 834 (8 aspas, 34 grados))
4. Potencia del motor (por ejemplo 2 HP).
5. Fases del motor (por ejemplo 3 Fases)

Ejemplo: AXB-150-834-2-3

TABLAS DE CAPACIDAD EN PCM

TAMAÑO	HP	RPM	PRESIÓN ESTÁTICA EN " c.a.															
			0"	1/8"	1/4"	3/8"	1/2"	5/8"	3/4"	7/8"	1"	1¼"	1½"	1¾"	2"	2¼"	2½"	
Modelo 834	1/4	1,582	2,620	2,340	2,050													
	1/3	1,740	2,881	2,630	2,380	2,110												
	1/2	1,994	3,302	3,080	2,870	2,630	2,400											
	3/4	2,285	3,784	3,600	3,410	3,210	3,010	2,800										
	1	2,514	4,162	4,000	3,820	3,630	3,460	3,270	3,090									
	1½	2,881	4,770	4,640	4,470	4,320	4,170	4,000	3,850	3,680	3,520							
	2	3,169	5,250	5,100	4,970	4,830	4,690	4,550	4,420	4,270	4,120	3,820						
	3	3,632	6,010	5,900	5,780	5,660	5,540	5,420	5,300	5,170	5,050	4,790	4,530	4,250				
	5	4,306	7,130	7,020	6,930	6,830	6,740	6,630	6,530	6,430	6,330	6,120	5,910	5,680	5,470	5,250	5,020	

LAS CAPACIDADES INDICADAS SON PARA AIRE LIMPIO Y SECO A 21° C Y CON DENSIDAD DE .075 LB/PIE3



Ventiladores Tubo Axiales

Transmisión de poleas y bandas

AXB

TABLAS DE CAPACIDAD EN PCM

TAMAÑO	HP	RPM	PRESIÓN ESTÁTICA EN " c.a.															
			0"	1/8"	1/4"	3/8"	1/2"	5/8"	3/4"	7/8"	1"	1¼"	1½"	1¾"	2"	2¼"	2½"	
182	Modelo 834	1/4	1,205	3,704	3,280													
		1/3	1,325	4,073	3,680	3,250												
		1/2	1,518	4,668	4,330	3,970	3,580											
		3/4	1,740	5,350	5,050	4,740	4,420	4,090										
		1	1,914	5,885	5,620	5,340	5,030	4,760	4,460									
		1½	2,193	6,744	6,520	6,270	6,020	5,770	5,510	5,250								
		2	2,412	7,418	7,220	6,990	6,760	6,540	6,310	6,070	5,830							
		3	2,764	8,500	8,320	8,130	7,930	7,740	7,550	7,350	7,150	6,950	6,520					
5	3,277	10,075	9,930	9,770	9,600	9,440	9,280	9,120	8,950	8,780	8,440	8,090	7,730					

TAMAÑO	HP	RPM	PRESIÓN ESTÁTICA EN " c.a.															
			0"	1/8"	1/4"	3/8"	1/2"	5/8"	3/4"	7/8"	1"	1¼"	1½"	1¾"	2"	2¼"	2½"	
200	Modelo 427	1/4	1,380	4,300	3,560													
		1/3	1,518	4,733	4,080													
		1/2	1,740	5,424	4,870	4,180												
		3/4	1,994	6,216	5,750	5,200												
		1	2,193	6,338	6,420	5,930	5,370											
834	Modelo 834	1½	1,740	7,144	6,820	6,490	6,130	5,800	5,420									
		2	1,914	7,858	7,570	7,260	6,950	6,650	6,320	5,970	5,580							
		3	2,193	9,005	8,740	8,480	8,220	7,960	7,680	7,420	7,120	6,820						
		5	2,600	10,675	10,470	10,250	10,020	9,800	9,570	9,350	9,120	8,900	8,420	7,870				

TAMAÑO	HP	RPM	PRESIÓN ESTÁTICA EN " c.a.															
			0"	1/8"	1/4"	3/8"	1/2"	5/8"	3/4"	7/8"	1"	1¼"	1½"	1¾"	2"	2¼"	2½"	
245	Modelo 426	1/4	1,040	5,625	4,440													
		1/3	1,144	6,188	5,130													
		1/2	1,311	7,092	6,190	4,900												
		3/4	1,503	8,127	7,340	6,460	4,730											
		1	1,653	8,940	8,250	7,460	6,510	3,650										
834	Modelo 834	1½	1,283	9,836	9,340	8,830	8,310	7,740	7,120									
		2	1,412	10,820	10,360	9,900	9,430	8,940	8,430	7,850								
		3	1,618	12,400	12,000	11,610	11,200	10,800	10,360	9,920	9,430	8,940						
		5	1,919	14,700	14,370	14,030	13,690	13,360	13,020	12,660	12,290	11,920	11,130					
		7½	2,199	16,846	16,560	16,320	15,970	15,680	15,380	15,070	14,770	14,480	13,830	13,160	12,440			
		10	2,418	18,531	18,270	18,020	17,750	17,490	17,220	16,940	16,670	16,410	15,850	15,260	14,640	13,990	13,290	

LAS CAPACIDADES INDICADAS SON PARA AIRE LIMPIO Y SECO A 21° C Y CON DENSIDAD DE .075 LB/PIE3



Ventiladores Tubo Axiales

Transmisión de poleas y bandas

AXB

TABLAS DE CAPACIDAD EN PCM

TAMAÑO	HP	RPM	PRESIÓN ESTÁTICA EN " c.a.														
			0"	1/8"	1/4"	3/8"	1/2"	5/8"	3/4"	7/8"	1"	1¼"	1½"	1¾"	2"	2¼"	2½"
270	1/4	921	6,456	4,830													
	1/3	1,012	7,102	5,680													
	1/2	1,160	8,139	6,940													
	3/4	1,330	9,327	8,330	7,120												
	1	1,463	10,260	9,470	8,330												
	1½	1,676	11,758	10,980	10,130	9,130											
Modelo 425	2	1,228	12,423	11,780	11,140	10,470	9,820	9,050									
	3	1,408	14,237	13,680	13,100	12,560	11,980	11,410	10,780	10,070							
	5	1,670	16,878	16,400	15,930	15,460	14,980	14,510	14,010	13,530	13,020	11,790					
	7½	1,914	19,342	18,940	18,510	18,100	17,680	17,270	16,840	16,430	16,000	15,130	14,160				
	10	2,105	21,276	20,890	20,520	20,140	19,760	19,390	19,000	18,630	18,240	17,480	16,700	15,800	14,770		
	15	2,412	24,382	24,060	23,730	23,410	23,070	22,740	22,420	22,080	21,750	21,070	20,420	19,730	19,020	18,260	17,410

TAMAÑO	HP	RPM	PRESIÓN ESTÁTICA EN " c.a.														
			0"	1/8"	1/4"	3/8"	1/2"	5/8"	3/4"	7/8"	1"	1¼"	1½"	1¾"	2"	2¼"	2½"
300	1/3	809	8,328	6,250													
	1/2	927	9,544	7,850													
	3/4	1,062	10,937	9,550	7,430												
	1	1,168	12,031	10,800	9,200												
	1½	1,339	13,788	12,720	11,500	9,800											
	2	1,473	15,167	14,190	13,160	11,850	10,070										
Modelo 424	3	1,164	16,242	15,510	14,770	14,030	13,230	12,380	11,440								
	5	1,380	19,255	18,670	18,030	17,400	16,760	16,110	15,420	14,670	13,900						
	7½	1,582	22,066	21,530	21,000	20,440	19,900	19,350	18,790	18,200	17,600	16,320					
	10	1,740	24,273	23,800	23,300	22,800	22,300	21,800	21,300	20,770	20,260	19,170	18,000				
	15	1,994	27,817	27,400	26,980	26,540	26,110	25,690	25,250	24,800	24,360	23,470	22,520	21,550	20,500	19,260	

TAMAÑO	HP	RPM	PRESIÓN ESTÁTICA EN " c.a.														
			0"	1/8"	1/4"	3/8"	1/2"	5/8"	3/4"	7/8"	1"	1¼"	1½"	1¾"	2"	2¼"	2½"
330	1/2	788	10,852	8,500													
	3/4	903	12,436	10,600													
	1	993	13,680	12,030	9,670												
	1½	1,138	15,678	14,280	12,540												
	2	1,252	17,246	15,980	14,570	12,680											
Modelo 422	3	991	18,490	17,600	16,630	15,500	14,530	13,380									
	5	1,175	21,920	21,120	20,300	19,470	18,640	17,820	16,900	15,700							
	7½	1,347	25,120	24,470	23,770	23,040	22,340	21,600	20,840	20,040	19,230	17,400					
	10	1,482	27,640	27,020	26,370	25,740	25,090	24,440	23,800	22,400	21,090	20,880	19,220				
	15	1,698	31,670	31,100	30,550	30,000	29,450	28,900	28,340	27,730	27,180	25,980	24,700	23,330	21,920		

LAS CAPACIDADES INDICADAS SON PARA AIRE LIMPIO Y SECO A 21° C Y CON DENSIDAD DE .075 LB/PIE3



Ventiladores Tubo Axiales

Transmisión de poleas y bandas

AXB

TABLAS DE CAPACIDAD EN PCM

TAMAÑO	HP	RPM	PRESIÓN ESTÁTICA EN " c.a.														
			0"	1/8"	1/4"	3/8"	1/2"	5/8"	3/4"	7/8"	1"	1¼"	1½"	1¾"	2"	2¼"	2½"
365	1/2	717	12,052	9,270													
	3/4	822	13,812	11,500	7,220												
	1	904	15,194	13,140	10,200												
	1½	1,036	17,412	15,680	13,550	10,050											
	2	1,140	19,153	17,570	15,780	13,480	9,000										
Modelo 420	3	862	20,660	19,500	18,370	17,150	15,600	13,800									
	5	1,022	24,490	23,480	22,490	21,410	20,330	19,210	17,980	16,400							
	7½	1,171	28,070	27,220	26,330	25,400	24,510	23,580	22,620	21,630	20,500						
	10	1,283	30,870	30,100	29,320	28,510	27,710	26,880	26,000	25,100	24,220	22,170					
	15	1,476	35,380	34,700	34,030	33,320	32,620	31,920	31,200	30,440	29,700	28,120	26,450	24,500			

TAMAÑO	HP	RPM	PRESIÓN ESTÁTICA EN " c.a.														
			0"	1/8"	1/4"	3/8"	1/2"	5/8"	3/4"	7/8"	1"	1¼"	1½"	1¾"	2"	2¼"	2½"
402	3/4	662	15,930	12,800													
	1	729	17,522	14,770													
	1½	835	20,080	17,730	14,780												
	2	919	22,088	20,000	17,500												
Modelo 426	3	711	24,242	22,770	21,220	19,580	17,700										
	5	843	28,740	27,490	26,200	24,900	23,530	22,040	20,270								
	7½	967	32,936	31,880	30,730	29,600	28,470	27,300	26,080	24,630	23,000						
	10	1,064	36,229	35,280	34,250	33,230	32,200	31,160	30,070	28,930	27,710	24,800					
	15	1,219	41,518	40,700	39,800	38,900	38,000	37,100	36,200	35,300	34,330	32,300	30,000				
	20	1,341	45,670	44,900	44,080	43,300	42,480	41,680	40,860	40,030	39,230	37,480	35,600	33,580	31,100		
	25	1,445	49,187	48,470	47,730	46,980	46,240	45,500	44,730	43,980	43,200	41,660	40,030	38,280	36,370	34,190	

TAMAÑO	HP	RPM	PRESIÓN ESTÁTICA EN " c.a.														
			0"	1/8"	1/4"	3/8"	1/2"	5/8"	3/4"	7/8"	1"	1¼"	1½"	1¾"	2"	2¼"	2½"
445	1	621	20,070	16,390													
	1½	712	23,000	19,850	15,730												
	2	784	25,310	22,500	19,100												
	3	898	29,000	26,600	23,900	20,300											
Modelo 424	5	758	32,070	31,300	29,610	27,920	26,030	23,850									
	7½	869	37,790	36,350	34,880	33,400	31,860	30,240	28,500	26,760							
	10	956	41,560	40,300	38,950	37,600	36,230	34,840	33,380	31,730	30,030						
	15	1,096	47,630	46,530	45,360	44,180	43,010	41,830	40,620	39,360	38,080	35,200	31,550				
	20	1,206	52,420	51,440	50,380	49,330	48,270	47,200	46,100	45,000	43,880	41,520	38,920	35,730			
	25	1,299	56,450	55,520	54,550	53,570	52,590	51,610	50,600	49,570	48,540	46,500	44,250	41,850	38,930		

LAS CAPACIDADES INDICADAS SON PARA AIRE LIMPIO Y SECO A 21° C Y CON DENSIDAD DE .075 LB/PIE3



Ventiladores Tubo Axiales

Transmisión de poleas y bandas

AXB

TABLAS DE CAPACIDAD EN PCM

TAMAÑO	HP	RPM	PRESIÓN ESTÁTICA EN " c.a.														
			0"	1/8"	1/4"	3/8"	1/2"	5/8"	3/4"	7/8"	1"	1¼"	1½"	1¾"	2"	2¼"	2½"
490	1	537	23,110	18,000													
	1½	615	25,480	22,350													
	2	677	29,130	25,400	20,400												
	3	776	33,380	30,250	26,500												
	5	921	39,570	37,000	34,100	30,750	26,250										
Modelo 422	7½	727	42,860	41,000	39,050	37,050	34,950	32,700									
	10	800	47,140	45,450	43,700	41,930	40,070	38,140	36,100								
	15	917	54,020	52,530	51,020	49,540	48,000	46,380	44,720	42,950							
	20	1,009	59,420	58,330	56,720	55,300	53,910	52,500	51,030	49,520	48,000						
	25	1,087	64,000	62,780	61,500	60,220	58,940	57,630	56,300	54,900	53,520	50,570					
	30	1,155	68,030	66,870	65,680	64,480	63,270	62,030	60,800	59,500	58,210	55,550	52,730				

TAMAÑO	HP	RPM	PRESIÓN ESTÁTICA EN " c.a.														
			0"	1/8"	1/4"	3/8"	1/2"	5/8"	3/4"	7/8"	1"	1¼"	1½"	1¾"	2"	2¼"	2½"
542	1	454	26,600	19,300													
	1½	520	30,500	24,800													
	2	572	33,500	28,500													
	3	656	38,400	34,200	28,400												
	5	778	45,500	42,000	38,100	32,600											
	7½	891	52,200	49,100	45,800	42,100	38,000										
Modelo 420	10	682	54,000	51,700	49,300	46,800	44,200	41,500	38,500								
	15	782	61,800	59,800	57,800	55,800	53,600	51,400	49,100	46,700	43,800						
	20	861	68,000	66,200	64,400	62,600	60,600	58,700	56,600	54,400	52,300	17,300					
	25	927	73,200	71,700	69,800	68,200	66,300	64,600	62,700	60,900	58,900	54,700	19,800				
	30	985	77,900	76,300	74,700	73,200	71,500	69,800	68,200	66,500	64,700	60,900	56,700	51,900			

TAMAÑO	HP	RPM	PRESIÓN ESTÁTICA EN " c.a.														
			0"	1/8"	1/4"	3/8"	1/2"	5/8"	3/4"	7/8"	1"	1¼"	1½"	1¾"	2"	2¼"	2½"
600	1	367	30,300	17,500													
	1½	421	34,700	27,100													
	2	463	38,200	31,700													
	3	531	43,800	38,100	29,900												
	5	630	51,900	47,300	41,800	31,400											
Modelo 426	7½	568	60,000	56,000	51,500	46,900	41,000										
	10	625	66,000	62,300	58,400	54,400	50,000	43,500									
	15	717	75,700	72,700	69,200	65,900	62,200	58,500	53,700								
	20	789	83,200	80,400	77,900	74,300	71,200	67,900	64,500	60,600							
	25	850	89,600	87,000	84,200	81,500	78,500	75,700	72,500	69,200	65,500						
	30	904	95,300	92,800	90,200	87,700	85,000	82,100	79,200	76,300	73,200	65,500					

LAS CAPACIDADES INDICADAS SON PARA AIRE LIMPIO Y SECO A 21° C Y CON DENSIDAD DE .075 LB/PIE3

DIMENSIONES GENERALES

en pulgadas

Modelo AXB

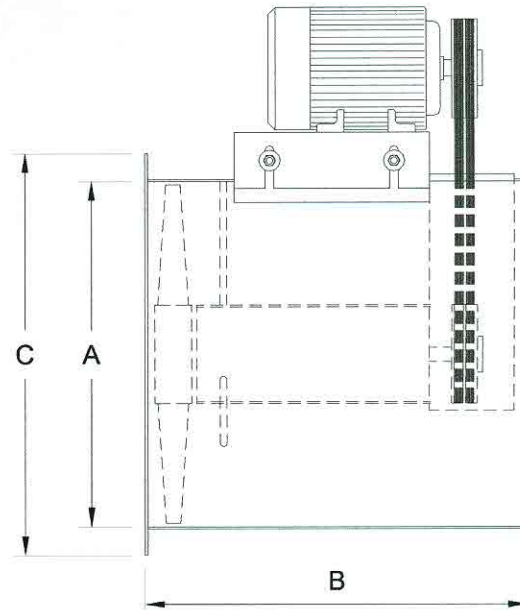
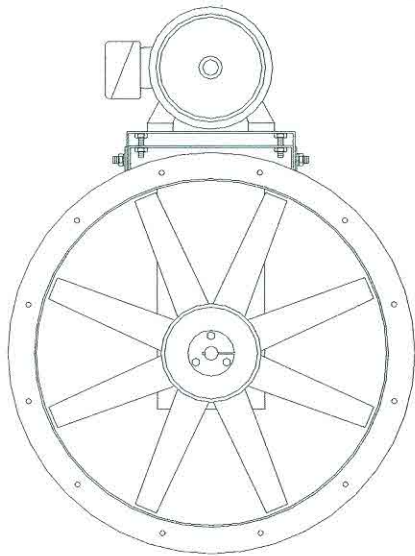

TAMAÑO	A	B	C	Diam flecha	PESO*
150	15	19	18	1	19
182	18 1/8	19	21 1/8	1	22
200	20	19	23	1	23
245	24 1/2	31	28 1/2	1 3/16	39
270	27	31	31	1 3/16	43
300	30	31	34	1 7/16	49
330	33	31	37	1 7/16	73
365	36 1/2	31	40 1/2	1 7/16	103
402	40 1/4	35	44 1/4	1 11/16	134
445	44 1/2	35	48 1/2	1 11/16	173
490	49	35	53	1 11/16	193
542	54 1/4	35	58 1/4	1 11/16	212
600	60	38 1/2	64	2 3/16	342

*Peso del ventilador en kilogramos, sin motor ni transmisión.



VENTAS INSTALACIONES Y SERVICIO, S.A.



VICENTE EGUIA 4-202, COL. SAN MIGUEL CHAPULTEPEC, 11850, MEXICO, D.F.
 TELS. 52-73-39-24 52-73-39-72, FAX 52-73-40-44, vissa@infosel.net.mx, vissa.ventas@gmail.com